

FIRST ANNOUNCEMENT AND CALL FOR PAPERS







3rd International Conference & Exhibition on Integrated Environmental Management in Southern Africa

ESKOM Conference Centre

Johannesburg, South Africa
27 – 30th August 2002



Jointly organised by:

	<p>University of the Witwatersrand, Johannesburg, South Africa</p>  <p>SCIEM Basel Centre For Innovative Environmental Management</p> <p>SCEE Basel Chair In Environmental Engineering</p>
	<p>Gerhard-Mercator University of Duisburg, Instrumental Analytical Chemistry, Germany</p>
	<p>South African Institution of Chemical Engineers, Johannesburg, South Africa</p>

Current Sponsors: Ministerium fur Schule, Wissenschaft und Forschung des Landes
NRW, Germany

INVITATION

You are invited to attend the 3rd International Conference on Integrated Environmental Management in Southern Africa (Sub Saharan Africa) to be held in Johannesburg, South Africa, from August 27 to August 30, 2002, one week ahead of the Johannesburg Earth Summit¹. The conference is being jointly organized by the University of the Witwatersrand, SCIEM Centre for Innovative Environmental Management, Johannesburg, South Africa and Gerhard-Mercator University of Duisburg, Instrumental Analytical Chemistry, Germany.

The focus of the conference is "Integrated Environmental Management in Southern Africa – Contribution to the New Millennium in Africa". The conference aims to emphasize the most important environmental issues and the need to improve environmental management in Africa. It will aim to contribute to the development and implementation of new and innovative environmental management policies and approaches for Africa as well as to provide a platform for discussing and presenting new methods, tools and technologies.

The subject of the conference is of concern nationally, regionally and internationally. This is due to the increased need for technology and knowledge transfer, historical learning experiences, emerging consciousness about the role and importance of Africa in the global environmental management. Africa also needs to become a leader in environmental protection and management due to its unique resources of global importance.

By reviewing environmental problems in Southern Africa and current solutions, the conference aims to identify the areas of the most pronounced priorities and to provide an input to the Earth Summit and contribute to appropriate solutions for managing the African environment in the future.

The conference will also focus on Environmental Education in Southern Africa and its role for the future.

¹ **The World Summit on Sustainable Development (also known as Rio + 10)**, will be a summit gathering from 2 - 11 September 2002 in Johannesburg, South Africa, of world governments, concerned citizens, United Nations agencies, multilateral financial institutions and other major actors to assess global change since the historic United Nations Conference on Environment and Development (UNCED), of 1992.

The CEMSA 2002 Conference

During the last few years, the development of environmental management, regulation and control techniques has progressed in most African countries. In Southern Africa, several countries are reviewing the existing environmentally related policy and legislation in line with new challenges, contemporary international experiences and integrated environmental management principles and approaches.

With the Earth Summit on Sustainable Development to be held in Johannesburg, South Africa, during the first week of September 2002 Southern Africa will be in the focus of international environmental community. Many research and other environmental management projects are being carried out throughout the region to respond to the focused global interest on Africa.

This conference will promote the transfer and exchange of the latest information and know-how on environmental management and related problems in an attempt to provide a significant contribution to the Earth Summit deliberations. The conference will also provide a good opportunity for the engineer, scientist, researcher, consultant and professional practitioner to network with others, discuss key issues and open up business and other opportunities.

The conference will focus on the major issues in the following topics:

1. Environmental Management

- a. Policy Evolution,
- b. Legislation, Regulation and Enforcement
- c. Methods and Tools for Environmental Management
- d. Technology for Environmental Management
- e. Environmental Economics
- f. Social Aspects and Public Participation

2. Contemporary Environmental Problems of Sustainable Living

- a. Transboundary Environmental Problems
- b. Industrial Environmental Problems
- c. Agricultural Environmental Problems
- d. Mining and Environment
- e. Health & Environment

3. Solutions to Contemporary Environmental Problems

- a. Industrial Ecology
- b. Environmental Technology
- c. Environmental Processes
- d. Information Technology and Information Systems
- e. Environmental Monitoring, Data Analysis
- f. Remote Sensing and Analysis
- g. Analytical techniques

4. Environmental Capacity Building

- a. Education & Training
- b. Life Long Learning

- c. Curricula Development
- d. Resources for Capacity Building
- e. The role of higher education institutions

5. Disaster and Environmental Impacts

- a. Disaster Management and Preparedness
- b. Natural and man made disasters

The conference will run over 4 days and it is expected that during the first 3 days a joint plenary session each morning will be assigned to two keynote speakers (topics to be decided). Parallel sessions will be run after the joint session in which more specific issues of relevance to participants will be addressed. The fourth day will be devoted to round table debate on environmental problems of Southern Africa, appropriate international experiences and identification of the framework for the future. international cooperation and networks to bring the state of the art technology and know-how to Africa and to transfer African experiences to other parts of the world will be addressed.

Special keynote speakers will be selected to ensure the conference delivers the most up-to-date information and research results as well as the latest policy developments in environmental engineering, science, management, policy and regulation worldwide.

Throughout the conference time will be assigned for networking, poster presentations and an exhibition. On the evening of the second day, a formal dinner will be arranged. Optional field trips of interest to conference attendants will be available at extra cost. In addition pre and post conference trips for delegates and accompanying persons will be arranged, and publicised in the second announcement.

Call for Papers/Abstracts

Oral and poster papers & presentations are invited on any of the listed topics and related areas.

Abstracts should be submitted on line at www.cemsa.org or by email to cemsa2002@civil.wits.ac.za. Exceptionally, abstracts can be faxed to +27 11 403 8851 using the abstract submission form as attached. The abstract should include the study objectives, results and tentative conclusions.

Authors will be informed about inclusion of their presentations in the conference programme by the middle of January 2002 and the deadline for the submission of full papers is May 1, 2002. Instructions for the preparation of papers/posters are attached.

Call for Papers/Abstracts

Pre and post conference short courses/workshops on a number of topics will be organised. Details will be provided in the second announcement

Oral/Poster Paper Presentation

Oral papers will be allocated 20 minutes, of which presentation will occupy 15 minutes and discussion will take 5 minutes. Two people will chair each session. Poster papers will be provided with suitable presentation space to ensure authors are able to show and discuss their material to delegates.

All abstracts of conference papers will be printed in advance and made available at the conference, as will full papers on a CD. Papers selected by the scientific committee will be peer reviewed and published in JEMSA Electronic Journal soon after the conference.

Official Language

The official language of the conference will be English and will be used in all correspondence, presentations and publications.

Important Deadlines

Events	Date
Abstract submission	November 30, 2001
Notice of acceptance	February 28, 2002
Full paper submission	May 1, 2002
Paper review/comments	June 15, 2002
Final submission	July 15, 2002
Conference	August 27-30, 2002

Conference Fees

Item	Before May 1, 2002	After May 1, 2002
Delegates		
Full registration	US \$ 400	US \$ 450
Registration per day	US \$ 100	US \$ 125
Students		
Full registration	US \$ 150	US \$ 175
Registration per day	US \$ 50	US \$ 75
Accompanying persons		
Opening Ceremony		
Banquet	US \$ 30	US \$ 35
Field trip	US \$ 35	US \$ 40
	US \$ 25	US \$ 35

Delegates and/or students presenting papers or posters qualify for 25% discount on the above rates. In addition a number of fellowships will be made available for qualifying students/young researchers, presenting papers and/or posters (20). Priority will be given to students from African countries. Those interested should contact the organisers for appropriate fellowship forms.

WORKSHOPS SHORT COURSES



Exhibition and Fees

A formal exhibition will be organized should there be a minimum of 80 exhibitors attending the conference. In such a case each exhibitor will be provided with the following facilities:

An appropriate stand consisting of the following:

Floorspace , 2 X 220 Volt/15 Amp electrical power points, 2 X spotlights, 1 X table and 2 X chairs, 2 X plants on each side of the stand , Blue carpeting, Partitioning on 2 sides and at the rear of each stand , Cleaning of stand

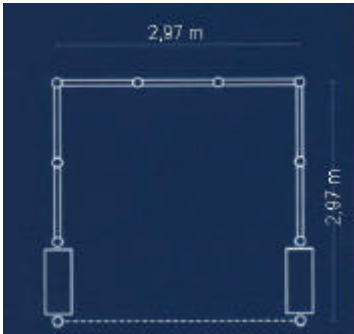
The pricing for each stand depends on the size as specified below. Prices for nonstandard sizes will be provided on request.

Floor space	Stand	Cost per day (2 days minimum)
9 m² Stand		US \$ 1200
6 m² stand		US \$ 1000

Should there be a smaller number of exhibitors an informal exhibition will be organized and appropriate fees will be published in the second announcement. Two ticket for the Conference will be included in the fee for the exhibitors

Exhibition area

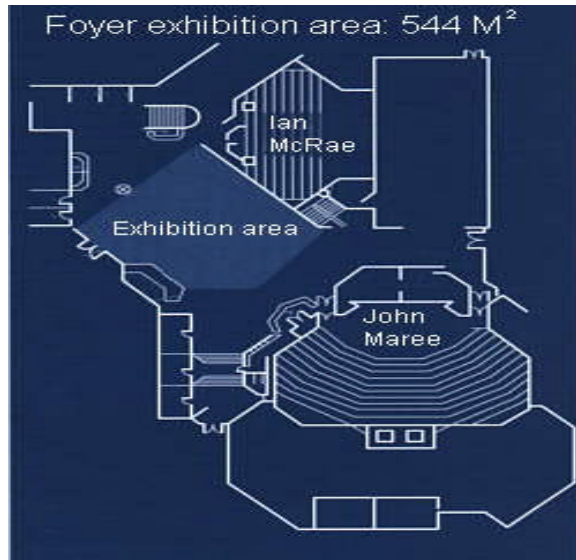

The foyer area between the John Maree and Ian McRae auditoriums can be converted into an exhibition area, offering a great variety of display options. Arranging an exhibition and a conference in tandem can be highly cost-effective as the exhibition will have a premium visibility with key audiences or delegates.

Within the exhibition foyer is a refreshment counter where tea, coffee and refreshments are served

The Venue

The conference will be held in the ESKOM Conference Centre, Midrand, Johannesburg.

Set in the tranquillity of the semi-rural highveld, Eskom Convention Centre provides a friendly ambience, superior service and outstanding venues where clients and their guests can feel right at home.

Eskom Convention Centre has all the convenient features you have come to expect of a professional conference centre:



- Easy access to airports - 30 minutes' drive from Johannesburg International Airport and barely five minutes from Grand Central Airport.
- Catering for a great variety of conference needs - state-of-the-art facilities for seminars, conferences, forums, workshops, promotions, exhibitions, banquets, and meetings of any form or size.
- Sumptuous catering for all occasions, indoor or outdoor.
- Overnight accommodation, economy to de luxe.
- Exciting recreational facilities.
- 24-hour security service and ample free and secure parking.

The John Maree Auditorium (350 seats) and the Ian McRae Auditorium (208 seats) each have adjacent built-in registration areas. A number of smaller venues with capacity of up to 60 delegates is also available.



Accommodation

The Eskom Convention Centre offers a wide spectrum of accommodation facilities, ranging from comfortable, inexpensive accommodation to the ultimate in luxury to cater for your needs and to suit your budget. All accommodation facilities are conveniently situated on the premises of the Eskom Convention Centre.

<p><u>De Luxe</u></p> <p>De luxe units offer comfortable furnished accommodation with en-suite bathrooms, air conditioning, television (including M-Net) and a communal lounge Indicative price: US \$ 100 per person (B&B)</p>	
<p><u>Standard</u></p> <p>Standard accommodation, each with TV, telephone and bathroom en-suite. Standard accommodation comprises single bedrooms with bathrooms en suite. These bedrooms are also equipped with heating, tea/coffee facilities and radio clocks Indicative price: US \$ 80 per person (B&B)</p>	
<p><u>Economy</u></p> <p>Affordable single accommodation with a washbasin in each room, and every four rooms sharing a bathroom.</p> <p>Economy accommodation comprises single bedrooms with wash basins and built-in study areas. Four bedrooms share a bathroom. Indicative price US \$ 50.</p> <p>Indicative price: US \$ 50 per person (B&B)</p>	

PRE REGISTRATION FORM

Surname: _____

First name: _____

Organisation: _____

Postal address: _____

Postcode: _____

Phone: _____ Fax: _____

I wish to attend the conference

Please send further details

I will submit a paper

I will present a poster

We would like to sponsor CEMSA2002,

please send us details

Preliminary title of the paper/poster:

WORKSHOPS

My company intends to exhibit and we need

6 m² stand

9 m² stand

Please forward the form to:

Prof. P. Marjanovic, cemsa2002@civil.wits.ac.za

Fax: +27 11 403 8851

or by post to PO BOX 592, WITS 2050, Johannesburg, South Africa

or register on line on www.cemsa.org

Organizing Committee

Prof. Prvoslav Marjanovic, Chairman, University of the Witwatersrand, S.Africa
Prof. Alfred Golloch, The Gerhard-Mercator University of Duisburg, Germany
Prof. P. Omara-Ojungu, University of Venda, S. Africa
Prof. Ignacy Cukrowski, University of the Witwatersrand, S. Africa
Prof. Otiano, Technicon of Witwatersrand, S. Africa
Dr. Gerd Fischer, The Gerhard-Mercator University of Duisburg, Germany
Dr. Ewa Cukrowska, University of the Witwatersrand, S. Africa
Dr. P Wolfmeyer, ZENIT GmbH, Germany
Pr.Eng Chris Albertyn, C&M C.Eng. and CAIChE, S. Africa
Mrs. Tiny Madiba, Department of Environment and Tourism, S. Africa
Ms. Lesley Stephenson, University of the Witwatersrand, S. Africa
Mr. Pierre Loots, SASOL SHE Centre, S. Africa
Mr. Fred van Zyl, Department of Water Affairs and Forestry, South Africa
Mr. Clive Govander, ABB, S. Africa
Mr. Luis Bayse, National Disaster Management Centre, S. Africa
Mr. James Brice, University of the Witwatersrand, S. Africa

Scientific Committee

Prof. Karl Molt, The Gerhard-Mercator University of Duisburg, Germany
Prof. Harold Annegarn, University of the Witwatersrand, S. Africa
Prof. Rasa Vidic, University of Pittsburgh, USA
Prof. Prvoslav Marjanovic, University of the Witwatersrand, S. Africa
Prof. Dr. Klaus R. Koch, University of Stellenbosch, S. Africa
Prof. John Cannon, University of Virginia, USA
Prof. Ignacy Cukrowski, University of the Witwatersrand, S. Africa
Prof. Diana Hildebrandt, University of the Witwatersrand, S. Africa
Prof. Alfred Golloch, The Gerhard-Mercator University of Duisburg, Germany
Prof. Andy Fourie, University of the Witwatersrand, S. Africa
Prof. G. Blight, University of the Witwatersrand, S. Africa
Prof. Pratiba, University of Botswana, Botswana
Prof. D. Savic, University of Exeter, UK
Prof. C. Maksimovic, Imperial College, UK
Prof. Han Klein, University of Zimbabwe, Zimbabwe
Dr. Krisno Nimpuno, Office for Disaster Preparedness for Africa, S. Africa
Dr. Ewa Cukrowska, University of the Witwatersrand, S. Africa
Dr. Evans Kaseke, University of Zimbabwe, Zimbabwe
Dr. Pieter Steaghaman, SASOL R&D, S. Africa
Dr. Peter Literati, Vituki Institute, Hungary
Dr. Zoran Cukic, University of the Witwatersrand, S. Africa
Dr. Heinz-Martin Kuß, The Gerhard-Mercator University of Duisburg, Germany

Dr. H-D. Stock, Landesumweltamt NRW, Germany
Dr. Bob Swap, University of Virginia, USA
Dr. Branko Cavric, University of Botswana, Botswana
Mr. B. Gumbo, University of Zimbabwe, Zimbabwe

Contact Details

CEMSA 2002

Prof. P. Marjanovic

SCIEM Centre for Innovative Environmental Management
School of Civil & Environmental Engineering
University of the Witwatersrand
WITS 2050, Johannesburg, South Africa

Email: cemsa2002@civil.wits.ac.za

Fax: +2/11/403 8851

Tel: +27/11/717 7123

WEB: www.cemsa.org

OR

Prof. Dr. A. Golloch / Dipl.Ing. Gerd Fischer The Gerhard-Mercator University of Duisburg,

Instrumental Analytical Chemistry

D-47048 Duisburg

Email: cemsa2002@lims.uni-duisburg.de

Fax: +49/203/379-2108

Tel: +49/203/379-3311 or 2578